

HP	A	B	C	D	E/E	F	G	H	I	J	K	KK	L	LL	M	N	O	OO	P	PP	Q	S	T	U	V	W	X	Y	Z	FAN WGT.	SHAFT CLASS III	SHAFT SIZE CLASS III
1050	10 1/2	8	11 3/4	22 1/16	14 15 1/2"	13 1/4	19 1/8	5 3/8	8 1/16	10 1/8	16	16 3/4	32 5/8	32	9 1/4	13 1/2	10	13	11 3/4	14 3/4	27 5/8	17 3/16	25 1/4	23 1/8	23 7/8	2	4	9 1/8	1 1/2	155	1"	1 7/16"
1225	13 1/4	9 1/2	12 1/2	23 7/8	13 3/4 15 3/4"	16 1/2	22 1/4	5 3/4	10 1/8	11 5/8	17 1/2	16 3/4	34 3/8	34 1/8	12 1/2	15	11 1/2	13	15	14 3/4	30 5/8	20 3/8	26 1/4	24	25 3/4	2	2 3/4	9 7/8	1 1/2	185	1 3/16"	1 7/16"
1500	16 1/4	12	15 3/4	29 3/8	17 3/8	20 1/4	26 1/4	7 1/8	12	14 1/8	18 1/2	18	38 5/8	38 7/8	16 1/4	17 1/2	12 1/2	14	18 3/4	19 1/2	34 1/8	25 1/4	32 5/8	30 5/8	31	2	3 1/2	11 1/8	1 1/2	245	1 3/16"	1 11/16"
1825	20 1/4	14	19	34 3/8	20 1/2	24	32	8 1/4	13 7/8	16 3/8	20 3/4	19	44 1/8	44 5/8	20	20	14 1/2	15	22 1/2	22 3/4	35 5/8	29 5/8	38 1/2	36 1/4	37	2	3 1/2	13 1/4	1 1/2	350	1 7/16"	1 11/16"

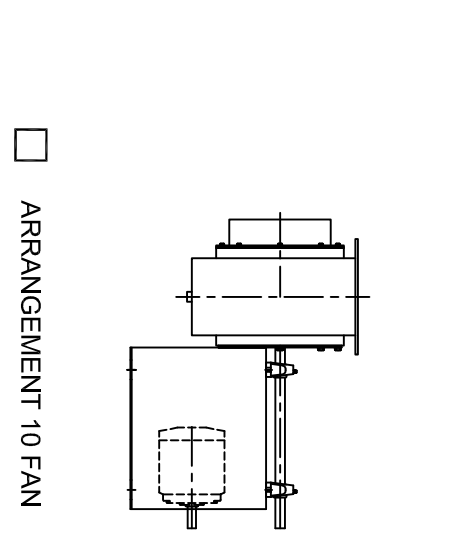
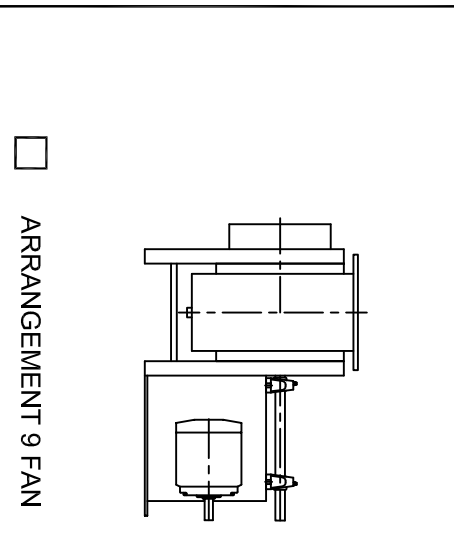
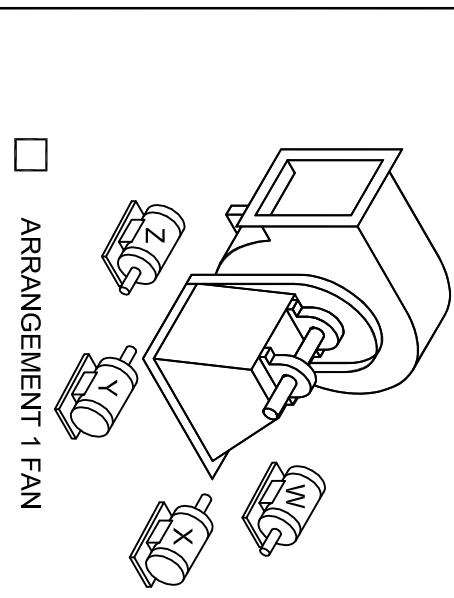

ENVIRONMENTAL ENGINEERING

Ontario, CA 91764 www.hee-llc.com Ph: 909.230.6120

HPC SERIES FRP FAN

S.O.: DWG: SHT OF